

--	--

--

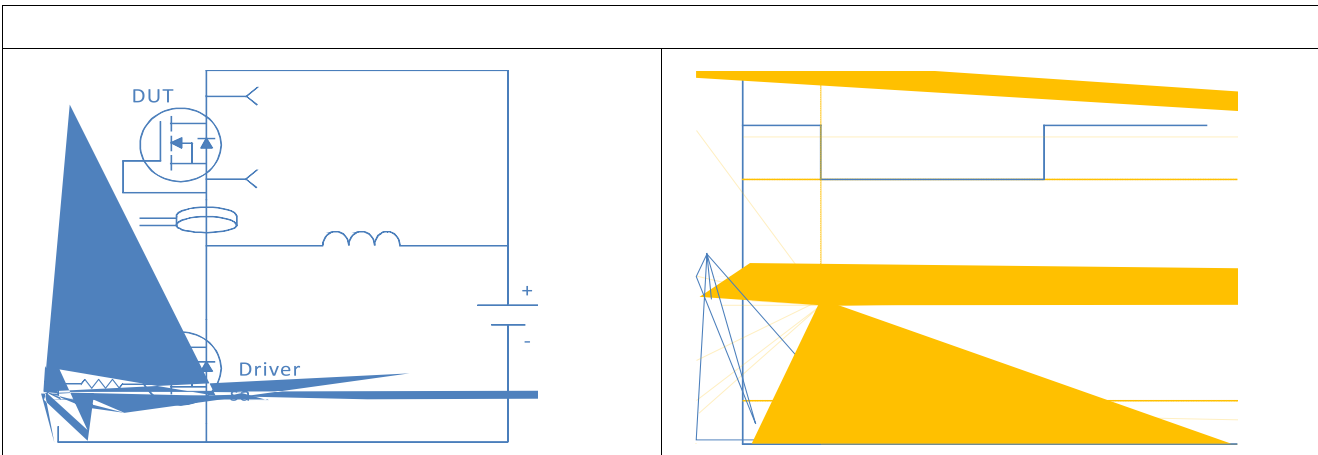

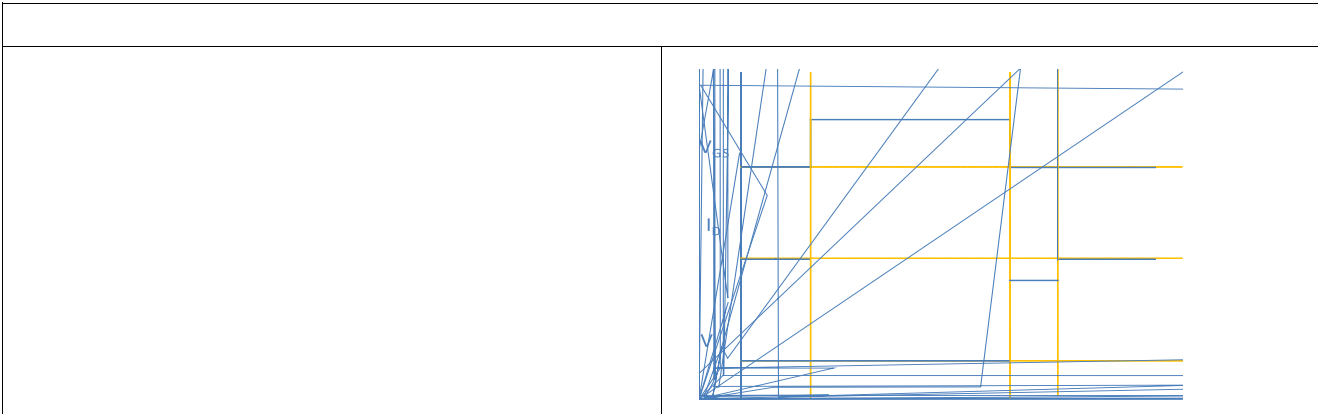
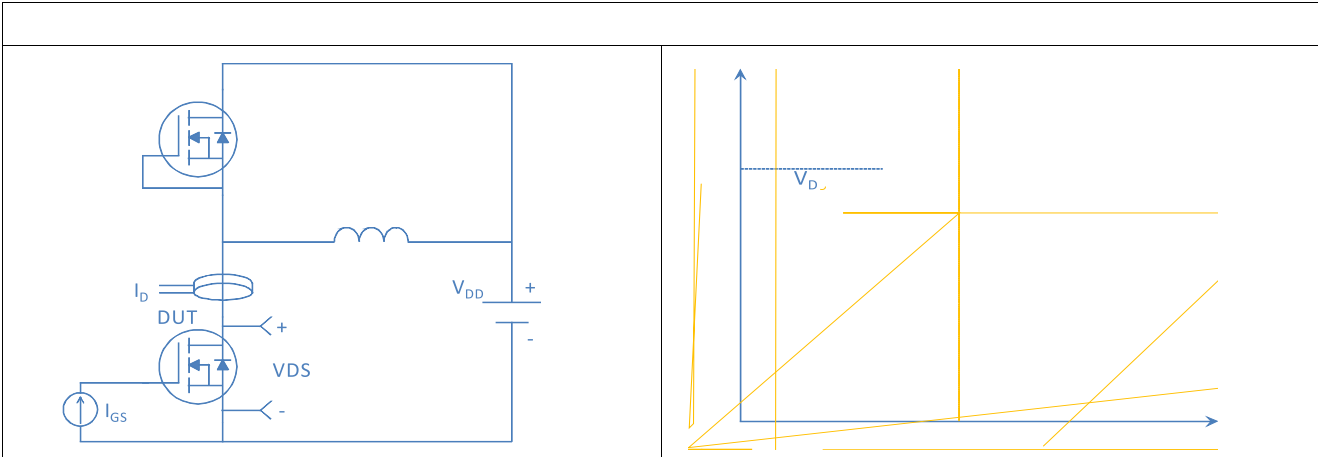
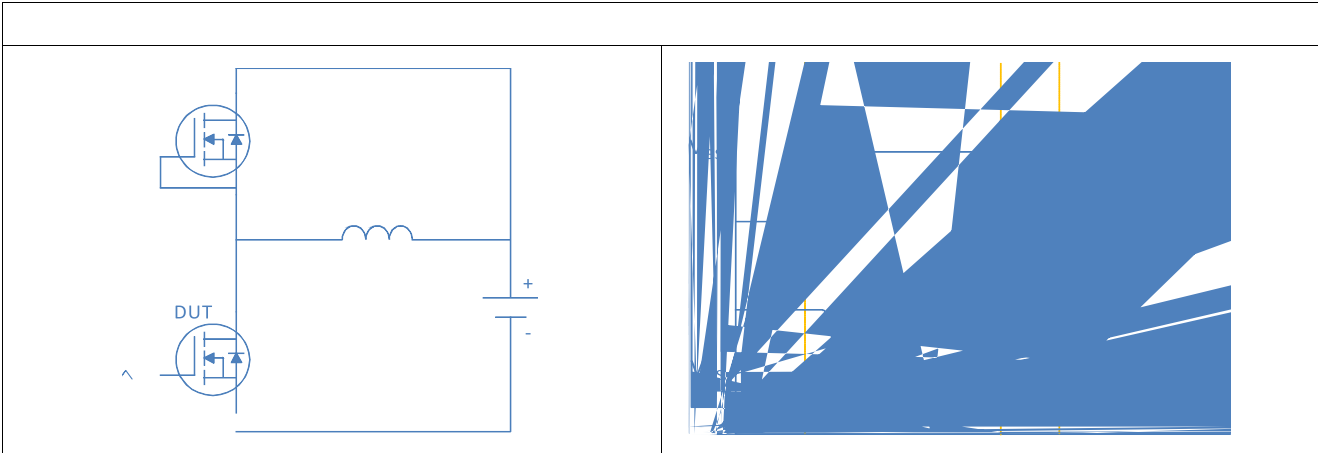
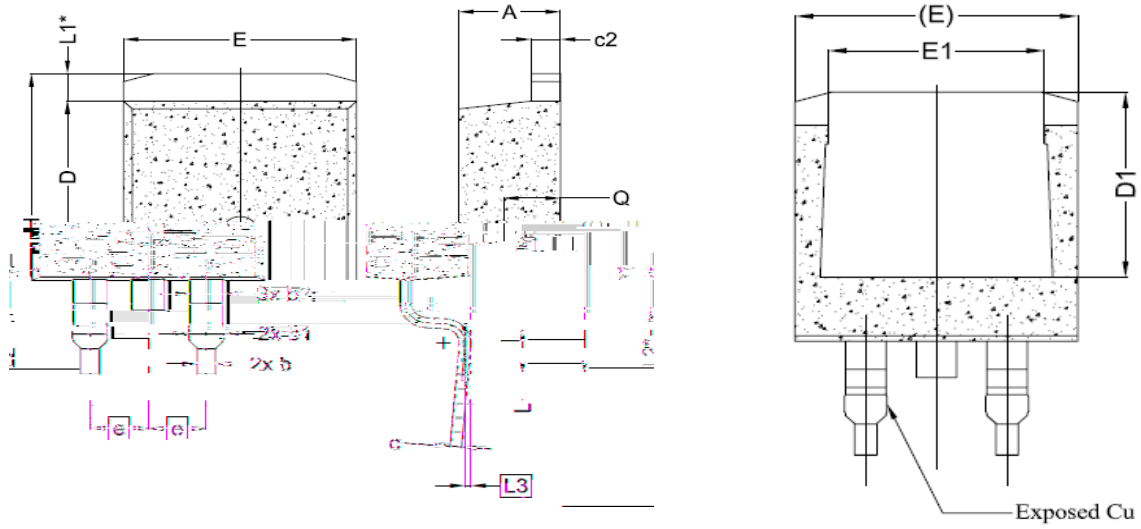

SYMBOL	DIMENSIONS		
	MIN.	NOM.	MAX.
A	4,24	4,44	4,64
A1	0,00	0,10	0,25
b	0,70	0,80	0,90
b1	1,20	1,55	1,75
b2	1,20	1,45	1,70
c	0,40	0,50	0,60
c2	1,15	1,27	1,40
D	8,82	8,92	9,02
D1	6,86	7,65	

E	8,82	8,92	9,02
E1	6,86	7,65	7,65
e	2,54 ±0,02		
H1	14,61	16,30	16,30
L	1,23	2,30	2,30
L1	1,35 REF.		
L2	1,50 REF.		
L3	0,25 BSC		
Q	2,30	2,46	2,70

